

**Milos
Litec
JTE
Tomcat
EXE Technology
Mobiltechlifts
Xtruss
Xstage**

**Magazine
of Area Four
Industries
Issue 3**

A4

**Looking back,
Moving forward – Frantisek Zyan
Fabio Prada – Direction of the group
Spotlight on new products
A4i.tv
Brands & Projects
Education
Customer challenges**

www.areafourindustries.com





Looking back, Moving forward

Frantisek Zykan

CEO, Area Four Industries
& Managing Director, Milos

In this candid and revealing article, Frantisek opens up about the beginnings of Area Four Industries and how it has progressed over the years.

My name is Frantisek, a normal guy from the Czech Republic, and I founded Area Four Industries. It's currently the world's largest group in the stage production and construction industry. Number one. We build structures around the world for concerts and live performances, such as The Rolling Stones, Metallica and Cirque du Soleil. How did I do it? Well, if you want something, you just have to do it. That's how I've lived my whole life. I don't believe in big visions. Rather, I just do what I feel is the right thing to do.

We have factories and offices in the Czech Republic, Germany, Britain, Italy, America and China. And we sell our products all around the world.

I started this business at home, which is in the city of Roudnice nad Labem in the Czech Republic. It's a small city, but a very nice and friendly place. Actually, I can't say that we started in a garage, since we didn't even have a garage. We started in a disco. We didn't have any extra equipment, so we used what was available and fully enjoyed the work we were doing. We just did it.

We didn't have much experience and wondered what we would do with our lives. So together with my DJ friend, we set up a light and sound production company. It was the only area where we had gained a little knowledge. We named the company Milos, which was my grandfather's name. In fact, the company is still called Milos today.

But let's go back to the start of the company. The partnership with my friend didn't last long. He left the company to pursue other interests and I remained alone. We basically had nothing, just a few basic necessities. It was at this point that I said to myself I had to do something if I wanted to get this company off the ground.

Aluminium was the the material of the future at that time, so I bet everything on it. I started to produce aluminium structures, which began to sell over time. The smaller structures were the first to sell, then the bigger ones and finally the biggest ones. I was forced to go to Germany, because the best structural engineers were there and could do the calculations. There was really no other option at the time. I can confirm that it wasn't very fun.

After building up my experience in Germany, I started making trips to America and opened a branch office there in 2000. Thus began global expansion of the company.

It was an incredible start, but I always had one dream: Establish a business and succeed in China. It seemed possible, so I just did it by opening a branch office and factory in 2007. The products manufactured in China satisfy the needs of Southeast Asia, which includes India, Japan and New Zealand. For two years, I was flying between the Czech Republic and China. It was challenging, as I was spending two weeks in China and then two weeks at home, but I stayed true to my dream and it paid off.

In 2012, we bought a competitor based in England. It was owned by people associated with Black Sabbath, but weren't musicians, so they were building structures instead. They had a good name in the industry, but didn't want to continue running their business. No one was interested in buying their company, so I bought it and did the same as I had always done before.

In 2018, we launched our own online Internet TV channel, A4i.tv, which features videos from four of our brands: Milos, Tomcat, Litec and JTE. A4I stands for Area Four Industries. I gave the company this name as I didn't want to have a name that included "Group" in it. Almost every company is using this word and I wanted something different. We are currently the biggest company in the industry, but still have a long way to go. The current trend is portable structures that support large LED screens, and we are therefore currently focusing on them.

People often ask me the secret of my success. I don't think there's a secret to reveal. I just continue moving forward and never give up. I believe that you have to set a goal and take the necessary steps to reach it. And every step you take needs to be the right one. But when you spend the necessary time and put forth the effort, you can do it. You just have to make sure that you get up and actually do it!

In conclusion, I would like to leave you with one last thought. The next time you're at the concert of your favourite band, and I'm thinking of a really big band, remember what it took to get them there.



Direction of the group

Fabio Prada

**Sales & Marketing Director, Area Four Industries
Managing Director, Litec**

In this wide ranging interview, Fabio answers questions about the activities of Area Four Industries and their brands, as well as their ongoing educational workshops and new internet TV channel.

What are the plans for Area Four Industries Group in 2019?

Our direction this year is simple. We are focusing on increasing our range of products, gaining a larger worldwide market share, promoting the visibility of our brand portfolio and building on our past steps and activities. Not to mention improving our year-end financial results!

Area Four Industries Direct was launched this year. What does this mean and how is it different from Area Four Industries?

To state the essence of Area Four Industries Direct, we can say that Area Four Industries is the brain and Area Four Industries Direct is the arm.

Area Four Industries Headquarters is our "think tank". It is where we discuss, strategize and make long-term plans for our direct distribution offices and portfolio of brands.

Area Four Industries Direct is the natural extension of all manufacturing companies within the Area Four Industries group, and consists of a team of extremely skilled professionals with deep knowledge of entertainment industry trends and the constantly changing dynamics within this field of business. Their daily focus is to improve the flow of communication between the professional end-user and our manufacturing companies.

What are the current trends in the entertainment industry? Are customer needs and requirements changing?

The biggest trend is in the industry can be summarized in one word... BIGGER! Bigger shows, bigger structures, and bigger loading demands. The sky is the limit!

Customers are searching for a tailor-made solution that brings a touch of uniqueness to their projects. Due to our wide portfolio of brands and extensive product range, as well as custom design and engineering services, we have a wide array of possibilities that can always satisfy our customers' needs.

The growing popularity of EXE Technology products is impossible to ignore, with everyone in the industry speaking about them. What are the reasons for their increasing success?

The brand is only 5 years old, but it's true that it has experienced a tremendous amount of success in such a short amount of time. I believe the reason for this is not only due to the high quality construction and intelligent design of EXE Technology products, but also the talented team supporting it. They listen closely to the industry's needs and funnel this information into the constantly evolving design and production process for innovations and improvements to EXE Technology products.

We see the trend of your Milos brand producing larger and stronger structures (for example, their Steel Truss line). Do you see this trend continuing in the future?

Definitely. The trend for the past 30 years has been increasing load capacity requirements. This trend even continues today and was the impetus for creation of the Milos steel truss line, as well as the Litec MyT Steroid line of high capacity aluminium truss.

The new image and direction of your James Thomas Engineering brand in the EMEA region is an interesting development. Can you tell us a little more about this brand and what it is offering to customers in this area of the world?

JTE is a one of the most popular manufacturing brands of truss in the world and also one of the most mature. We're giving it a good injection of innovation, with the introduction of modern and trendy truss solutions, while staying true to what contributed to this brand's success. But more importantly, we want to provide continuity to customers who have made investments in JTE products over the years by maintaining availability of these products going forward.

The Area Four Industries Group is focused on providing on-going trussing and rigging education to industry professionals, as well as to end users. Why is there a push in this direction?

In terms of trussing and rigging education, our focus is twofold. We want to provide users of our products with the knowledge and hands on experience that help them use our products correctly and safely. This is done with workshops our brands carry out each year and the annual Rigger's Voice forum Area Four Industries holds each year with the industries' top professionals.

Secondly, we want to share our deep well of experience and knowledge to benefit the industry as a whole. This is done through our recently launched rigging and trussing internet TV channel, www.A4i.tv, where we continuously create product, rigging and design basics videos, as well as on-site and other educational videos that are continuously produced and uploaded to this TV channel throughout the year.

As a result of these on-going educational activities, we are doing our part to help ensure that professionals who work in the trussing and rigging field (even if they are not our customers), as well as the people who attend live events where truss and support structures are used, will all benefit.



**Spotlight
on new
products**

Milos Ultimate Hinge

New angles in creative lighting

The new design of the Milos Ultimate Hinge allows for up and down and side-to-side movements of your truss spans! Constructed from aluminium truss and a steel hinge, it provides you with high strength, reliability and safety. It also features a high strength lifting eye for convenient connection with your electric hoists. The Ultimate Hinge connects seamlessly with Milos M290 truss, allows for the use of various conical connectors for extended compatibility and eliminates potential damage to book corners.

Ultimate Hinge is the direct result of a customer's request during last year's Prolight+Sound exhibition in Frankfurt, Germany. At Milos, we don't only listen to our customers and users. We act upon their suggestions and create the products they require!

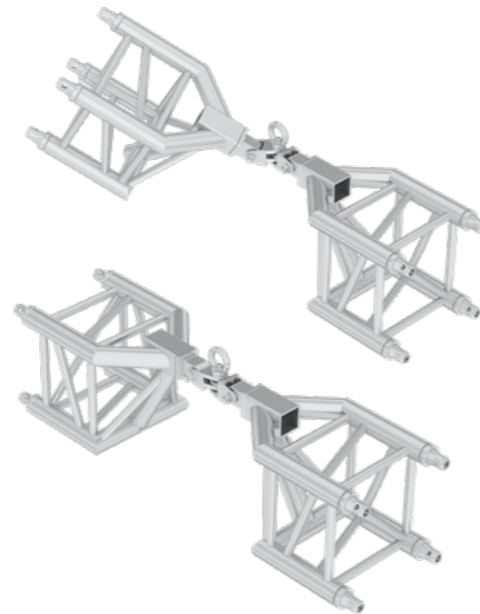

Milos Corner Brace HD

Quick roof construction, Increased stage access

The Milos Corner Brace HD is a new, advanced roof corner reinforcement concept that eliminates the need for guy wires in Milos small to medium-sized roof structures! Compared to guy wires, installation is greatly simplified and the total time for roof construction is noticeably decreased. Its strong, yet compact, all aluminium design provides the same strength and stability as guy wires, while giving your staff and performers increased access to the stage due to the elimination of rear and side cross guy wires.

Experience advanced roof reinforcement with the new Milos Corner Brace HD.

Technical information:

- Made from durable aluminium
- Provided with all connection material

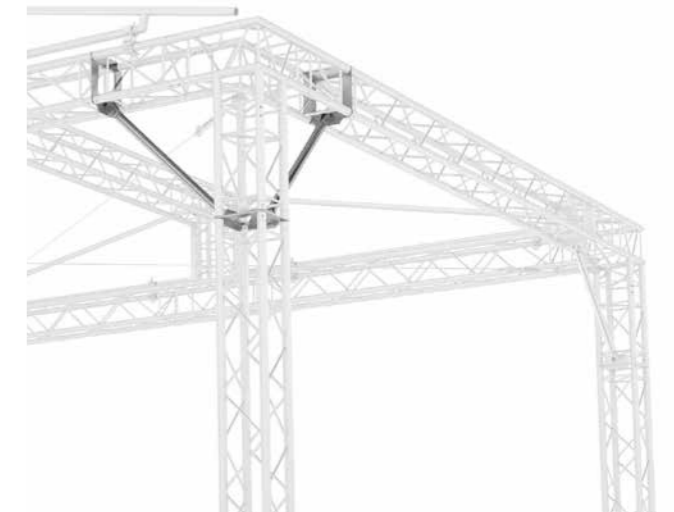

Milos Armor Cart

Safe and Secure Hoist Transport

Introducing Armor Cart, a new hoist utility vehicle that provides safe and convenient transport and storage for up to four of your hoists. Constructed from light and durable aluminium, the Armor Cart comes in two versions – model MAC-01-4025-A1 holds 4x 250 kg hoists and model MAC-01-2100-A1 holds 2x 1,000 kg hoists.

Due to its compact form factor, and possibility of stacking Armor Carts on top of each other, transport volume is reduced up to 50% compared to flight cases. In addition, its open air design reduces humidity within the interior and allows your hoists to dry faster, thereby helping to prevent corrosion.

Discover the safety, convenience and space saving advantages the Armor Cart provides for transport and storage of your hoist stock.



Milos Meat Rack

The new Meat Rack from Milos gives you a convenient transport and storage solution for lights, using adjustable light bars and hanging adapter for oversize lights, or just about anything else with its height adjustable shelves.

- All welded construction for high strength and long-term durability
- Made from high-quality 6082 aluminium
- Fork lift pick-up points for convenient stacking
- Height adjustable handle on each rack end for easy handling
- Castor wheels as standard
- Light bars, oversize light adapter or shelves on request
- 2.3 m x 0.8 m x 1.6 m (L x W x H) dimensions optimize transport space





Litec Pre-Rig 60 Revolution

A Revolution in Pre-Rig Truss Design

Litec's Pre-Rig Revolution is the most innovative, and revolutionary, solution for carrying moving lights mounted on pre-rig truss. Specifically designed for Touring, this special truss is designed without bracing on the underside, which allows moving or fixed lighting fixtures to be pre-rigged inside the truss before arriving at the venue.

Contrary to standard truss, the PR60 Revolution allows one person to mount moving light fixtures by themselves. Once the Teflon equipped skate carriages are mounted on the moving lights, they can easily slide into the truss along two "C" profiles, which act as rails. A set of steel pins secure the lights into almost any position along the length of the truss!

Use of bulky flight cases is no longer necessary, and consequently, transport space is dramatically reduced. But more importantly, lighting set-up/breakdown is faster and more efficient at the venue, since everything is already loaded up and ready to go.

Litec's PR60 "pre-rig truss" Revolution, and its dedicated line of accessories, allow for the permanent attachment, storage and transportation of a wide range of lighting equipment.

Each pre-rig "dolly" comes with foldable and height adjustable legs, together with caster frames, for easy transport and manoeuvrability during load in/out operations. To decrease storage space, dollies can be stacked on top of each other.

Key benefits:

- Truss lengths: 200 and 300 cm, as well as custom dimensions on request
- Truss connection via a dedicated "fork" system, available in 90° Step Rotation
- CE certified
- Fixed or adjustable height dollies sold separately
- Finishing: Natural or Powder Coated
- Custom colours and finishes available on request
- Accessories, such as horizontal gates, vertical gates, additional light bars and double vertical/horizontal forks are also available



Litec L-Wall System

Customizable LED Screen Support

Litec now offers a new ground support system for LED SCREEN WALLS – the L-WALL SYSTEM. This new product allows for maximum flexibility, combined with extreme precision and very fast set up times, to create small to big screens without adding additional loading to the roofing system.

The new L-WALL SYSTEM is designed for small/medium/large LED SCREEN WALLS and provides the possibility to connect LED WALL panels, usually 50 x 50 cm, at each of its attachment points.

When using the L-WALL SYSTEM as a support structure for your LED WALL installations, assembly times are dramatically reduced and you are provided with an extremely robust frame that firmly holds your screen in position.

Its modularity also makes it possible to add additional reinforcement with other elements in the rear of the structure to ensure the safest situation possible.

The fork connection system allows you to create arches for different configurations, as well as a support system for horizontal use.



Litec DADO Corner 30

Increased Corner Flexibility

The new tailor-made DAD CORNER 30 adaptor, which has been designed for use with the DADO STD or DADO HD 30 x 30 cm, allows you to create a half-meter corner with all possible direction combinations. It also provides increased convenience and efficiency, as the mounting of this adaptor to the DADOs is much faster and easier than with a classic half spigot connection system.

Litec LiteCAD Evolution

Bring Your Structural Ideas to Life

LiteCAD Evolution is a user-friendly Computer-Aided Design program specifically engineered to configure Litec Truss and their relevant accessories in multiple applications.

This software allows technicians to quickly create the structure they have in mind and propose it to their clients. Furthermore, it instantly lists all components needed, with technical data, such as weight and the space it occupies. It is possible to upload .dxf files, such as theatre drawings, and build-up a structure. LiteCAD Evolution allows you to perform all of these operations without needing any special knowledge of the CAD world.

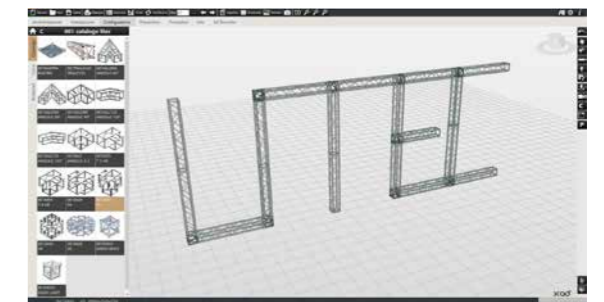
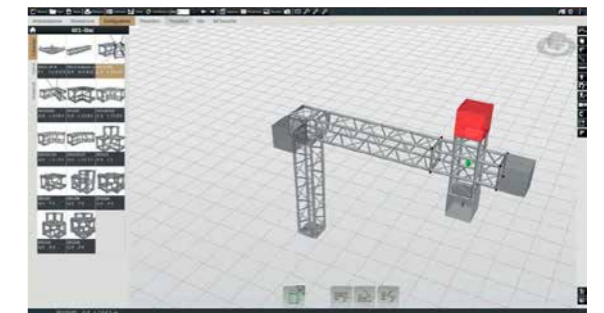
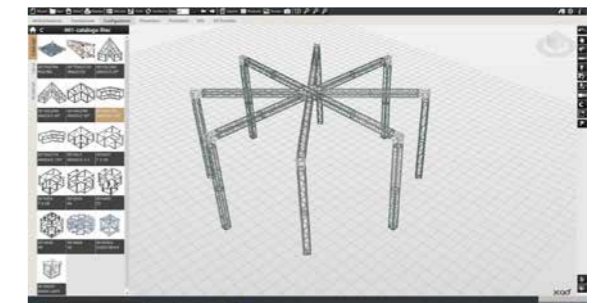



Tomcat Nemesis

Answering the call of the market

Nemesis is the arch-enemy of competing pre-rig truss. Its innovative design, which was inspired by customer requirements, greatly reduces the time required to load your fixtures and provides increased flexibility.

Its side-loading feature makes it possible for one person to load fixtures into the truss during prep using side legs that support the truss during the loading operation. In addition, the side channels can be mounted in two locations within the truss if smaller fixtures are used. A second set of channels can also be mounted, allowing fixtures to be offset as needed within the hang.



Tomcat Lighting Pod

Multiply the impact of your light walls

The extreme adjustability and flexibility of Tomcat's new Lighting Pod allow for the use of multiple lighting options within one framework that can be utilized both vertically and horizontally, allowing for "walls of light" on a much larger scale than with traditional truss profiles.

The Lighting Pod is constructed from 2" x 1/8" and 1 1/2" x 1/8" tubes for strength and durability, and measures a healthy 6' x 2' 6" x 6' (L x W x H) for extending your lighting wall possibilities. Stable stacking and convenient transport are ensured with steel spigots, forklift pockets and heavy-duty casters.

Tomcat Zig Zag Truss

Discover the folding advantage

Tomcat's new Zig-Zag Truss combines the advantages of Pre-Rigged Truss – efficient truck packing and speedy load-in/load-out – with a hinging spigot design that allows folding of the truss system over itself for efficient storage/travel and trouble-free unfolding via vertical lift and pinning applications.

The strength found in Zig-Zag truss comes from its 2" x 3/16" chords, 1 1/2" x 1/8" small horizontal tubes, 2" x 1/8" large horizontal/vertical tubes, and 2 1/2" x 1/8" diagonals. It also features steel spigots, 1/4" end plates and 2" round studs for extended stability and durability.

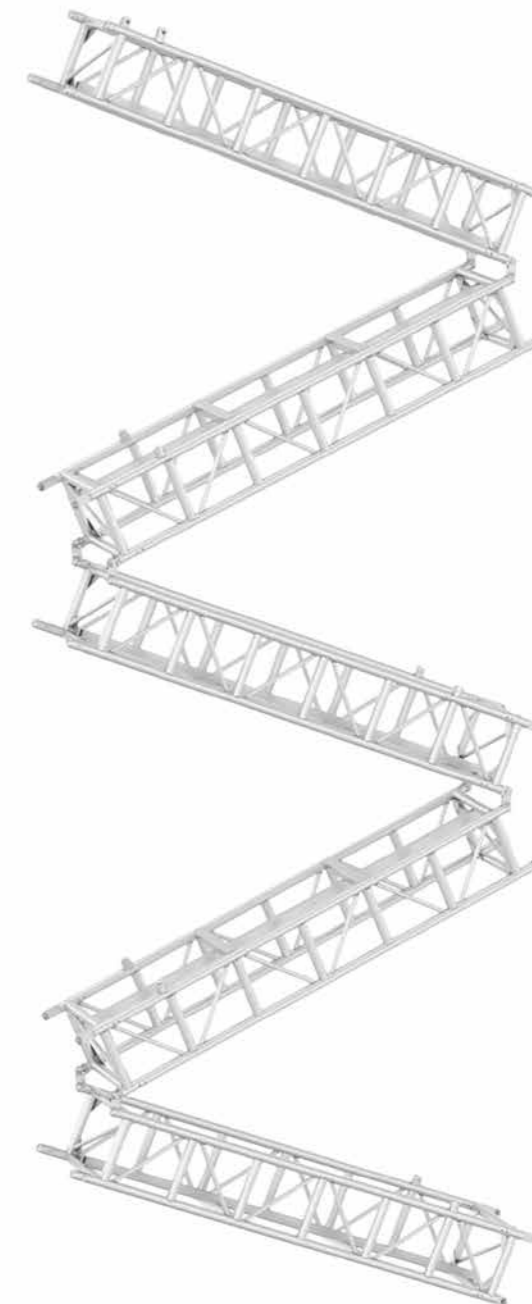
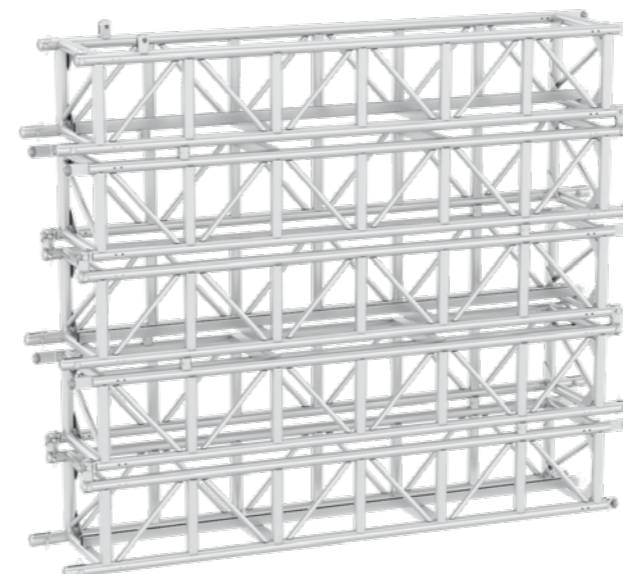

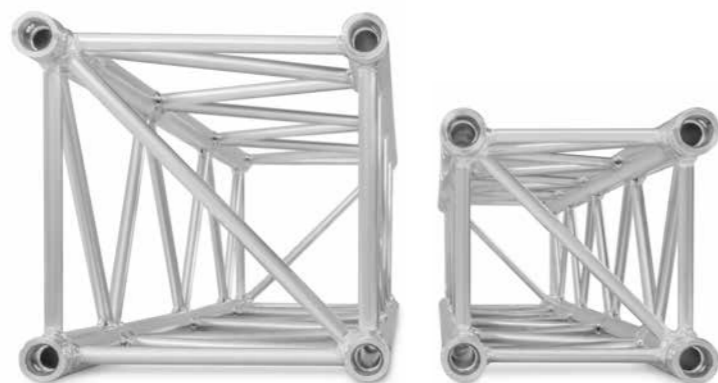

Conical Connectivity

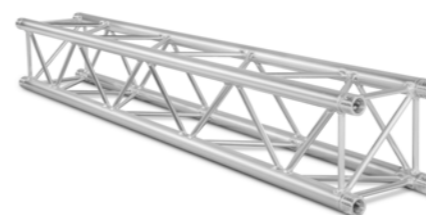

James Thomas Engineering JT30H

- Heavy-duty conical truss for indoor/outdoor multi-purpose use
- DUO, TRIO and QUATRO formats
- 48.3 x 3 mm aluminium tubes
- Width of 239 mm B.C.
- Versatile system widely used for PA Towers, Rigging Towers and Roofs
- Extended free-span (up to 20 m) and loading characteristics
- Wide range of accessories
- Compatible with JT-CELL 200/400/500

James Thomas Engineering JT40H

- Mid-sized, heavy-duty, conical truss for indoor/outdoor multi-purpose use
- DUO, TRIO and QUATRO formats
- High quality 48.3 x 3 mm heavy-duty aluminium tubes
- Width of 339 mm B.C.
- Extended free-span (up to 20 m) and loading characteristics
- Custom lengths, junctions and curves available
- Wide range of accessories
- Compatible with JT-CELL 200/400/500/600 series cell clamps
- Compatible with Xtruss accessories

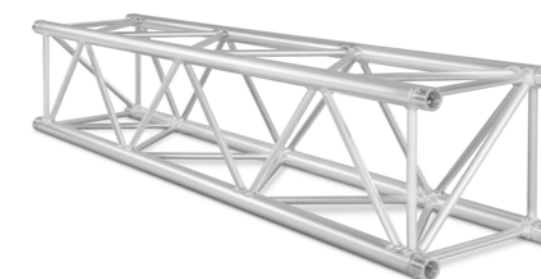

James Thomas Engineering JT22

- DUO, TRIO and QUATRO formats
- Width of 190 mm B.C. (Between Centre)
- Outstanding free span parameters considering its size
- Wide range of accessories
- Compatible with 130 series clamps JT-CELL
- Compatible with Xtruss accessories

James Thomas Engineering JT30

- Mid-sized conical truss for indoor/outdoor multi-purpose use
- DUO, TRIO and QUATRO formats
- 50 x 2 mm aluminium tubes
- Width of 239 mm B.C.
- Diagonal anti-twist end brace
- Extended free-span (up to 20 m) and loading characteristics
- Wide range of accessories
- Compatible with JT-CELL 200/400/500/600 series cell clamps
- Compatible with Xtruss accessories



EXE Technology

EXE Rise

“New” EXE Rise range now rated as D8+ chain hoists!

- Product range is now D8+ category (updated in accordance with the latest October 1st 2018 SQP2 German code of practice)
- FEM CLASS 2 m for small, medium and large frame chain hoists and FEM CLASS 3 m for extra large frame chain hoist
- Available in DIRECT CONTROL or LOW VOLTAGE configurations for both 400 V or 208 V 3-phase and single phase 110/230 Volts
- Two working positions – Body Up or Body Down
- Swivel body & chain hooks
- Chain bracket operates in self-climbing and body up positions
- Dual position handles – Makes hoist easy to handle in any orientation
- Handmade ballistic nylon chain bag for increased safety
- External PVC chain guide to protect chain and hoist body
- Aluminium chain hoist body
- Clutch positioned outside the line of kinetic movement
- Iron and asbestos-free brake shoes and stainless steel brake discs prevent brakes from seizing when exposed to moisture
- Possibility to equip the chain hoist with built-in load cell system for real time monitoring and encoder for position control
- IP55 rating



EXE Technology

2 Ton D8+ Single Fall

- Four Choices with D8+ Safety
- Single body configuration with 4 different modes;
 - Single reeve design: 2000 kg D8+ @ 4 m/min – FEM CLASS (9.511) 3M
 - Double reeve design: 4000 kg D8+ @ 2 m/min – FEM CLASS (9.511) 3M
 - Single reeve design: 2500 kg D8 @ 4 m/min – FEM CLASS (9.511) 3M
 - Double reeve design: 5000 kg D8+ @ 2 m/min – FEM CLASS (9.511) 3M
- Double brake on all versions
- 4 position limit switch by STROMAG in the LOW VOLTAGE version, with 96 metre travel range
- 5 pocket lift wheel
- Similar aesthetic body shape as the existing medium and large frame models
- 113 x 31 mm chain
- Swivel hook on body and chain
- Compatible with EXE CELL line of products both LC-PRO and NLP-16
- Same bag bracket concept as current range, with up to 50 metre chain (alternative versions on request)
- Four heavy-duty “built in” handles for convenient manipulation when out of flight case
- Double reeve option



EXE Technology

250 kg and 500 kg Single Phase

3 Phase power not available?
No Problem!

- Available in 250 kg (MEDIUM FRAME BODY) & 500 kg (LARGE FRAME BODY) loading capacity configurations
- Engineered & developed for use when 3-PHASE POWER is not available, such as on small locations or hotel conference rooms
- Uses exactly the same mechanical design as 3 PHASE version, but with a single phase motor



EXE Technology

EXE Cell

Shackle Load Measurements In Real Time

- 3.25 TON SHACKLE based LOAD CELL allows accurate weight measurements to be taken via one of the most commonly used pieces of rigging equipment
- Radial cable connection system ensures secure power supply to each cell



S10

Advanced design stage deck

The new S10 deck from Xstage delivers the top performance you require for your small to large live events. Its optimised profile, which reduces weight without sacrificing load capacity, and universal leg fastening system, make it a favourite among live entertainment professionals. Featuring a new indoor/outdoor, slip-proof hexagrip surface, and tough 12 mm birch plywood construction, it delivers long-lasting durability and safety. And as with all Xstage decks, it's in accordance with DIN 15921.

- Optimised profile around deck reduces overall weight to only 33 kg
- Universal leg fastening with cube lock system for trouble-free leg attachment
- Waterproof construction for both indoor and outdoor use
- 12 mm birch plywood deck provides heavy-duty strength and durability
- New hexagrip surface for increased traction in all weather conditions
- In accordance with DIN 15921

Technical Specifications:

Norm	DIN 15921
Load capacity	750 kg/m ²
Use	Indoor/Outdoor
Weight	33 Kg
Profile height	90 mm
Deck dimensions	2 x 1 m
Type of legs (mm)	Ø 48 mm, Ø 50 mm, 40 x 40 mm, 50 x 50 mm, 60 x 60 mm
Type of decks	Waterproof birch plywood
Deck surface	Slip-proof hexagrip surface
Deck thickness	12 mm
Height	200-1,500 mm

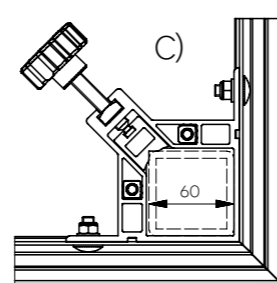
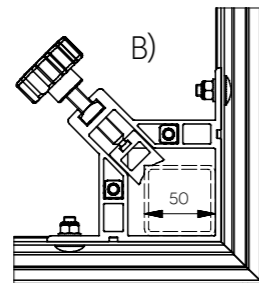
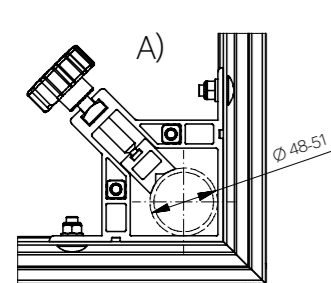

Xstage

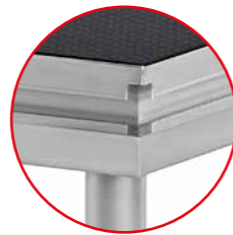
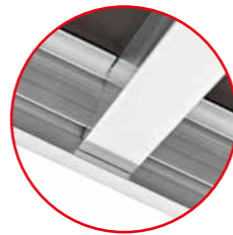

ML4

Leave the heavy lifting to us

The TÜV certified ML4 is a multi-purpose lift that packs 270 kg (595.95 lbs) of loading capacity into 6.5 m (21.33 ft). Featuring a unique pin locking system and heavy-duty steel pulleys, your hardware is protected against damage and safe operation is ensured at all times. Its height adjustable outrigger feet, with rubber pads for increased traction and surface protection, feature high profile threading for extreme heavy-duty use. Forks are available in both 0.5 m and 1 m lengths with allowable load vs. load position indicators. All bases in the ML4 series come with pre-equipped attachment points for horizontal installation of wheels for easy and convenient transport.











Rigging & Trussing Television

Categories

- ▶ Design Basics (1)
- ▶ Educational (16)
- ▶ On-site videos (10)
- ▶ Product basics (48)
- ▶ Rigging basics (11)
- Uncategorized (5)
- Velvet Backstage (1)

Commandos

-  Adam Beaum...
-  Michal Zykan
3 videos
-  Fabio Prada
1 videos
-  Norbert Tripp
9 videos
-  Eric Porter
10 videos
-  Will Todd
2 videos
-  Adrian F. Black
1 videos

Register now!

Register your email address now and get free updates!

Register now

JTE⁴
James Thomas
Engineering



LATEST TRUSSING & RIGGING VIDEOS



Norbert Tripp
Structural Report
a4i.tv / FEBRUARY 21, 2019 / 446 / 0



Norbert Tripp
How Truss Works - part 2
a4i.tv / JANUARY 30, 2019 / 89 / 0

EDUCATIONAL VIDEOS



Norbert Tripp
Structural Report
(Visited 446 times, 1 visits today)
a4i.tv / FEBRUARY 21, 2019 / 446 / 0



Norbert Tripp
How Truss Works - part 2
(Visited 89 times, 1 visits today)
a4i.tv / JANUARY 30, 2019 / 89 / 0



Norbert Tripp
How Truss Works - part 1
(Visited 222 times, 1 visits today)
a4i.tv / JANUARY 16, 2019 / 222 / 0

ON-SITE SHOOTING



LITEC
MyT Folding Steroid
San Paolo, Italy
(Visited 1526 times, 1 visits today)
a4i.tv / DECEMBER 5, 2018 / 1.53K / 0



LITEC Libera on the beach
(Visited 338 times, 1 visits today)
a4i.tv / JUNE 25, 2018 / 338 / 0



LITEC - MyT Folding Steroid - long
(Visited 358 times, 1 visits today)
a4i.tv / JUNE 25, 2018 / 358 / 0

RIGGING BASICS







Rigging & Trussing Television



Ales Roucek Marketing

We met with Ales to learn more about A4i.tv, the popular new Trussing and Rigging Internet TV channel that features design, educational, on-site, production and rigging basics videos.

A4i.tv – Can you tell us a little about this TV channel?

A4i.tv is an Area Four Industries project with a clear goal – to provide riggers with interesting information, educate the market and, last but not least, have some fun.

What was the reason for starting this project?

Education is one of the fundamental pillars of the Area Four Industries group. Simply put, if you want to be successful, you should not only focus on sales. You have to give something back to your market. In fact, the bigger you are, the more responsibility you have in the market. And with this in mind, we want to provide to riggers, whether they use our products or not, a continuous education that helps to increase their knowledge and the safety of their work.

So why are you focusing on video content? There are other ways to provide this information, such as blogs, etc.

We want to deliver this information to riggers in an easy to assimilate form. In today's world, no one wants to spend time reading long articles. Especially ones that are focused on technical subjects. We have chosen the video path because it is the easiest to understand for the people we are focused on. We also try to add comedic scenes in our videos, in order to make a very technical subject funny and more enjoyable to watch.

What is the main focus of A4i.tv?

We focus on 4 basic categories of content. The first is Rigging Basics, where we show proper and safe rigging techniques for building structures. Then we have Product Basics, where we present how, why and where to use products in various situations. Truss allows you to build a diverse range of buildings, and we want to show riggers how to build them easier and safer. Our Educational category of videos is meant to educate from a practical point of view, rather than being strictly theoretical, such as how to calculate static calculations that explain the internal and external forces experienced with a structure. And finally, we have On-site videos, where we show how our, and our competitors', products are used in real world scenarios.

Who is involved in the project?

We're a team of about nine people. This includes our "Rigging Commandos", who are the main presenters in our videos, as well as the people who shoot, edit and publish the videos. It's a lot of work, but we enjoy it.

What are the future plans for A4i.tv?

We have a lot of content that has already been created and we will publish it regularly and frequently. We are currently preparing new content as well for our viewers, as we want them to be an integral part of this project. We also plan to create a new area at A4i.tv, where riggers will meet and discuss subjects that interest them, regardless of where they live or the products they use.



Brands & Projects

Solid Ground... Raised

Xstage is a line of portable, modular stages made from high quality, extruded aluminium. Their legendary versatility, strength and durability suit a wide variety of applications – from traveling exhibits to concert tours. All stages are height adjustable, stable, easy to construct and feature compact storage. Additional accessories allow them to be used as catwalks, dance floors, and a host of other applications.



Lukas Tuzar
Brand Manager, **Xstage**

Within this brief interview, Lukas talks about the development and new-found independence of the Xstage brand, as well as their new S10 deck and future activities.

As the new Brand Manager for Xstage, can you tell us a little about yourself and your responsibilities?

I'm responsible for all activities related to the **Xstage** brand and its products. This includes the introduction of new products on the market, product promotion, customer service, and many other peripheral activities. In addition, it's very important to gather and analyze customer feedback for assisting in the continuous development and improvement of our product line so we keep up with current trends.

Xstage was previously manufactured under the Milos brand, but now Xstage products are an independent brand. What is the reason for this change and what does it mean for customers?

Xstage is what the **Area Four Industries** group calls a "horizontal" brand, which is similar to the **EXE Technology**, **Mobiltechlifts** and **Xtruss** brands. Horizontal brands supplement the core offering of the truss and support structure "vertical" brands within the **Area Four Industries** portfolio, thereby creating a grid matrix that fills the needs of our customers.

It's true that **Xstage** was under the **Milos** brand, but it had been planned years ago that it would eventually break out to become a horizontal brand within the group. The launching of the **Xstage** brand in 2018 was a natural development of the company due to an increase in staff, growth of production capacity and higher demand of **Xstage** products. Our product development and promotional activities have also increased with our new independence.

The **Xstage** product line is currently available from all **Area Four Industries Direct** distribution offices, which are located in the U.K., Germany and America. Our presence at these offices allows us to be more effective, have closer cooperation with our customers, and provide quicker reaction times.

A new product in the Xstage range is the S10 deck. What are the benefits of this new product?

The S10 deck is one of the lightest decks on the market, at just 33 kg, without sacrificing load capacity. It features a universal "cube lock" leg connection system that is compatible with a wide range of square and round legs. Its new main profile is also compatible with many competing decks. It's a complete staging solution for all kinds of events.

Can you tell us more about compatibility with decks from other manufacturers?

The new, optimized main profile of the S10 deck gives it a flexible advantage, as it ensures compatibility with many competing decks on the market. So you can use the S10 deck with other decks you may already have in your inventory.

Will other products in the Xstage range continue to be produced?

Yes, all products in our range will continue to be produced. Our goal is to keep a wide portfolio of products, so our customers are given the opportunity to purchase our new products in our range or continue using their current inventory of **Xstage** products.

What can we look forward to from Xstage in the future?

Now that we've finalized our new S10 range, we're focusing on development of our new **Xstage** Extended Height System. And as always, we're making daily improvements/adjustments to our current products.

Milos

The extensive product line from Milos includes aluminium truss, steel truss, temporary roofs, towers, LED support structures, crowd barriers, ramps, DJ kits, truss furniture, cell clamps, truss accessories and workwear. With factories located in the Czech Republic and China, it is equipped to satisfy the growing needs of its worldwide customer base.

Research and development at Milos is carried out on an ongoing basis, with many new and innovative products being introduced on the world market every year. Its internal Design and Engineering department works with Milos clients around the world on their custom and bespoke projects, helping to bring their ideas to life.

In 2018, Milos introduced its Steel Truss line, which addresses the entertainment industry's needs for larger and larger structures with constantly increasing load capacity requirements. Milos is currently the only truss manufacturer in the world that has a standard steel truss product line.

Fulldome Projection in South Korea

A massive, custom-designed, truss circle (22 metre diameter!) for a Fulldome projection system in South Korea. The custom circle, which serves to support lights and projection equipment, was constructed using specially designed, rectangular 850 x 990 mm Milos truss with 48 x 3 mm tubes. Each truss section includes ladder bars that enable staff to climb within the circle on-site to install the projection system equipment.

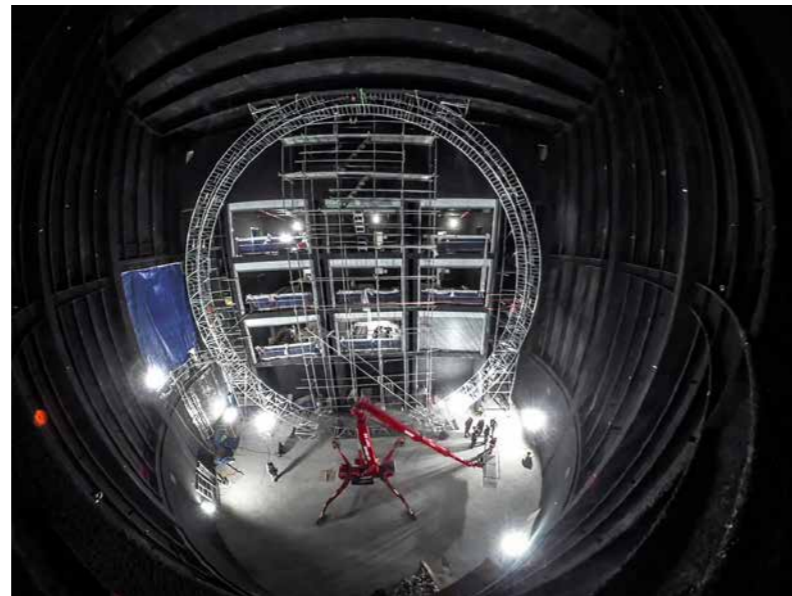

Lear puts their trust in Milos

Custom designed Milos support structures constructed with Milos M290B series truss for the new production hall of Lear Corporation Seating Slovakia, Ltd. (www.lear.com). The structure was designed to support power distribution (air, electricity and data) for machine equipment, lighting fixtures and control monitors.

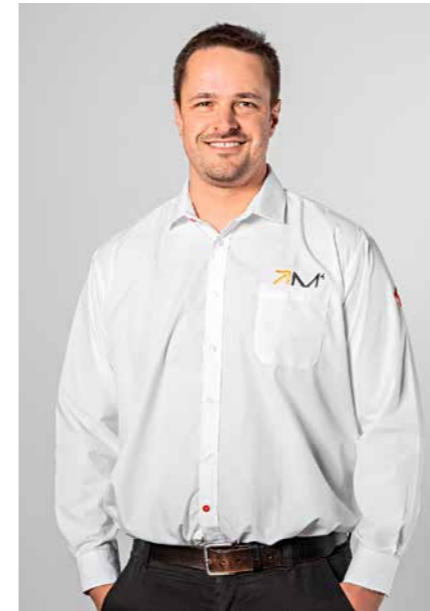

Marek Zubor Milos Brand Manager

Marek reveals the many new Milos products introduced this year, their ongoing activities with the new Milos steel truss line, and their plans for 2019.

Hi Marek. One year has passed since the last interview we had for A4 Magazine. Can you tell us about any new developments with Milos?

Our new steel truss line was launched last year and we have now doubled the production capacity by adding new sets of jigs to the production line. The number of dedicated welders with full certification for welding ultra high strength steel has also been doubled. And the steel truss line is now complete, with all models available to our customers.

Testing and certification of our truss line is constantly being carried out, which includes TÜV certification for our M390 RTL, M390 QTKT, M520 QTPT, M760 RTP, and M950 RTTH truss models.

Milos is increasingly flirting with steel. How has your new range of steel truss been accepted by the market, and is there a growing demand for these large and heavy load-bearing structures?

As I previously stated, we've made many improvements in the manufacturing of our steel truss line, which gives us the means to better serve the growing demand we've experienced for our steel truss products.

The first customer to invest in our steel truss line was the German company Malecon, which we've recently worked together with for the development and customization of a project that required a pair of steel spans for a concert in Dortmund, Germany by the famous German pop rock group PUR.

What new Milos products have you introduced, or will introduce, for your customers?

First, we have the Ultimate Hinge, which is an accessory that attaches to horizontal truss spans so lights can be hung vertically, horizontally or at an angle. It allows customers to be more creative with their lighting possibilities when using Milos truss as the support structure.

We also have our the new Armor Cart, which is an aluminium cart that holds, transports, and protects from two to four electric hoists. The Meat Rack is another product we will display. It serves as a transport and storage cart for lights or other accessories (with optional shelves).

For roof structures, we will introduce the Corner Brace HD, which provides support for small to medium-sized roof structures and eliminates the need for guy wires, thereby optimizing stage access and reducing the time required for build-up.

And lastly, we have our new AUTOCAD Library, which is available for download on the Milos website. It contains simplified DWG files, with descriptions and the most important information users require for working with our products.

Can you tell us about any new, interesting projects Milos has taken part in?

As I had mentioned before, we had worked on a very impressive project with our first steel truss customer Malecon. For this project, our steel truss was used for two 42-metre spans for support of lighting. The Area Four Industries Direct Germany office worked together with this customer for this project, and also engineered components for an octagon support structure made from aluminium truss that was used as a dynamic centrepiece above the stage.

Our aluminium truss has also been used for a chain of jumphouses in Germany, as well as for various Ninja courses in the United States.

I would also like to mention a very interesting project for our customer Getec Eventtechnik, which assembled a 16 x 12 m MR4 roof for the Andrea Berg stage at the Open Air Concert in Aspach, Germany. It was the largest structure they had ever assembled and was a huge success.

What are the plans for Milos in 2019?

We will continue developing and delivering high quality products to our many customers around the world. The shooting of educational and product videos, which really kicked into high gear in 2018, will also continue. Due to the increasing demands of the market, we plan to expand our welding production capacity by 20%. And we plan to add barcodes to all products within our extensive portfolio in the near future for better organization, tracking and inventory control of Milos products.

Litec

Litec is an "Italian based" company who designs and manufactures industry standard, aluminium "truss" systems and a wide variety of sizes and dimensions of "self-standing structures" for the entertainment, corporate, film/TV, concert touring, theme park and architectural market/applications.

Litec's mission is to offer innovative solutions that match the demanding expectations of its worldwide network of customers, while keeping an eye on market trends driven by the latest technological evolutions.

Litec relies on highly qualified staff, including design specialists and experts in production and quality, who work seamlessly and devote themselves to the creation of innovative solutions.

Research, innovation and design are strategic activities at Litec and they are the main factors for competing and growing on an international basis. They are the driving force to increase effectiveness and efficiency of the company as a whole.

Litec products comply with the highest standards of quality and safety, as they firmly believe high quality equals safety.

Litec has established itself over the last 20 years as a reliable, innovative partner that offers technologically advanced products and cutting-edge support services, strongly rooted in the company's values: design, quality, innovation, safety.



MyT Folding Steroid Roof System dominates in Naples

The MyT Folding Steroid Roof System, with spot and delay towers (constructed with MyT Folding Steroid's modular components), was used at the Tribute Concert in Naples, Italy for an audience of 85,000, and television audience of millions, that celebrated the life and songs of Italian singer Pino Daniele.

The Litec MyT Folding Steroid Roof System is a modular, completely self-contained roof environment that's a hybrid of folding EN AW-7003 T6 aluminium mother grid truss sections (allowing for a 63% decrease in width), 85 x 85 cm EN AW-6082 T6 aluminium towers and key structural elements in high strength S355 steel such as modular ballast bases, sleeve block and safety block. Integral structural parts are assembled without welding to optimize performance & eliminate issues related to heat affected zones.



Andrea Santello

Research & Development Manager, Litec

Andrea sits down with us and provides information about LITEC, their internal working processes, past projects and the evolution of customer needs.

Litec is a well-known brand that provides projects that are custom-tailored to the needs of its customers. Do you sometimes find it difficult or exhaustive to fulfill the visions of your customers?

I honestly find it exciting when a customer requests a bespoke project that requires a different point of view. The mission of Litec is to become the "tailor" of the industry. Most customers come to Litec with only an idea or a dream and our mission is to transform it into a structure.

How often do you find it necessary to reject customer requests?

Fortunately, up till now, we've never rejected a project. We work as a team and complement each other's specific skills. We take each demanding request as a challenge and like to deliver a winning solution.

What interesting projects have you realized in the past year?

I would like to highlight two specific projects carried out in 2018: A MyT Folding Steroid project for the set of a film and a structure to cover the sand nativity scene in St. Peter's Square in the Vatican.

The first project for the film set was a 33 m span of three parallel lines of MyT Folding Steroid truss with 2 tons of dynamic load in the center and Litec's DST52 to move the scene. The entire structure was assembled on the ground and then lifted with a crane because it was used at a 20 m height.

The structure in St. Peter's Square at the Vatican measured 21 x 10 m and was constructed with Libera FL76 truss and featured MT40 towers with rigid connections. For this project, the customer needed the cleanest and most elegant structure as possible with connections at the base. We delivered a system that kept all bases at the lowest possible height, so they were very close to the ground and could be covered with sand.

In the end, both customers were extremely satisfied, which is the goal we always try to achieve.

Are you physically present on the projects you work on, or is your work mainly with software and on the computer?

I'm physically present on the projects. I use software to draw the structure (AutoCAD or Solid Edge), but I prefer to do all calculations with pen and paper or, if it is something special, with Excel. I thoroughly enjoy being present for the duration of the project, and I'm often in the factory to check all products and their manufacturing.

As Research & Development Director, you are in charge of developing new products. Can you explain this process for us?

Research and development begins by identifying a function that cannot be performed by our current line of products. Everything often starts from a customer's request. I generally prepare a sketch on paper, or on AutoCAD, and then discuss it together with the R&D staff. When the idea and goal are defined, the senior 3D Designer, Marco Trabucco, proceeds to draw the product and step by step I calculate the dimensions, thickness and material. When the drawing is completed, we check its functionality and combine it with other products and, if all is fine, we proceed with a prototype. If the prototype meets all of our demands, we provide specifications to the sales team.

You've worked at Litec for many years. Do you see the customer needs changing as time goes on or do these needs remain relatively the same?

Requests have really changed over the years. The demand for larger, more detailed, and more performance-oriented structures has definitely increased. This was the reason for development of Litec's MyT Virtue line in 2017. Another important thing that has changed is the trend of having horizontal movement of LED screens during live shows. With the start of this trend, it was clear that Litec had correctly predicted this need, since a special application they had developed called the DST52 System then turned into a standard product that met with more and more interest from customers. Four years down the road, we can see that this truss system is a big success. Over time, we've further developed the DST66 system so it can hang more weight and can reach higher speeds – up to 1 m/sec. In the future, more and more structures will have to be large, perform at a higher level and be equipped to handle faster movement of LED screens.



James Thomas Engineering

Discover the new JTE conical truss series for the EMEA region, as well as the world-renowned plated and fork truss that made James Thomas Engineering famous around the world. From its impressive towers to high quality clamps and accessories, James Thomas Engineering has the products you need for a wide range of small to medium-sized projects.

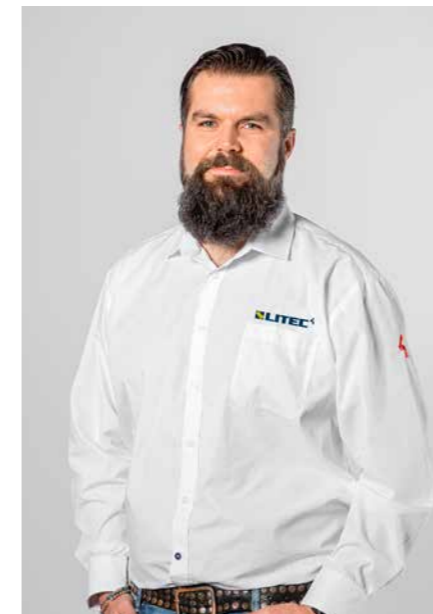
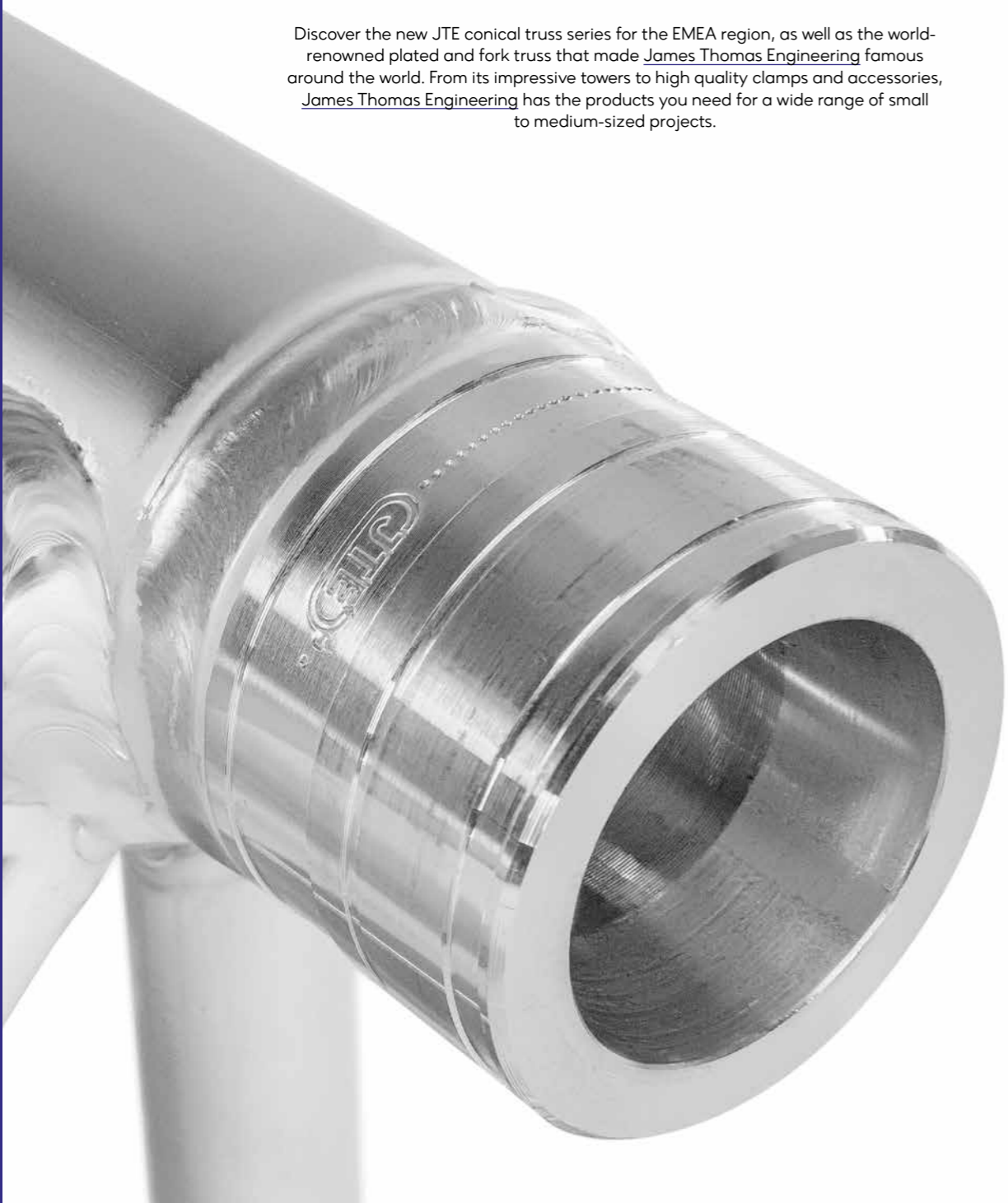

Jan Cernota
Litec Export Sales Manager

Jan Cernota has been very busy the past year with all of the new developments and changes with the JTE brand. We catch up with him to discuss their current activities and outlook for the future.

What have you and JTE been up to since we've last spoken together?

Well, we've been very busy with the promotion and production of the newest addition to the JTE family, our conical truss line, which provides safe and secure connection with other leading brands of conical truss. It's a new chapter in the long history of JTE and we're excited about it's future. We can already see that it's appreciated by our customers.

Will you be introducing any new products this year?

Yes, we will extend the Thomas Tower range with the new TT1 tower, which is based on JT30H conical truss. It's a compact, but heavy-duty, tower system that stands up to 7.5 m (24.60 ft) and features a specially designed sleeve block system and reinforced head section. Operation is ensured with a manual chain block or electric chain hoist (bracket required). It features guy wire connection points via bolt-on hangers and short or long outriggers are available.

What direction is JTE taking for 2019?

We're continuing to promote our new conical truss line and are gaining more and more customers. Of course, we'll also continue producing our lines of truss products for customers who have invested in JTE in the past. They can count on JTE products being available in the future.





Tomcat

Tomcat has been one of the strongest brands in the truss and support structure industry for many decades and continues to lead the market with its "Made in the USA" products that deliver "Strength Under Pressure". Tomcat is also one of the leaders in trussing and rigging education with its highly respected and well-known Tomcat U workshop that is held each year.

Tomcat has recently made significant investments in improving manufacturing processes and monitoring/tracking systems that will provide their customers with better traceability of their products, as well as

immediate access to precise and detailed information concerning their production and life cycle.

During the second half of 2018, a new monitoring system was introduced for Tomcat's welding processes based on QR code scanning. This new system greatly improves Tomcat's welding productivity during the manufacturing process by providing online information about the welder, product, welding operation and order number of each Tomcat product. A cutting edge web-based application is used with this new monitoring system that is independent for each Tomcat office

and all information is easily accessible to other business units in the company.

And if that wasn't enough, a new system for monitoring product serial numbers has also been introduced that effectively minimizes administration, prevents manufacturing mistakes, simplifies internal logistics and provides more precise data about each individual product's life cycle. As with Tomcat's new welding monitoring system, this process also uses a cutting edge web-based application that is independent for each location and all information is easily accessible to other business units in the company.



Will Todd
COO, Tomcat

Tomcat and America take centre stage as Will talks about the strength of Tomcat in the American market, exciting new products and projects, new trends, and the strong connection that exists between Tomcat and JTE.

Tomcat is one of the most important "truss" brands on the American market. What are the reasons it has achieved this level of success?

Tomcat carved out its place in the American market back in the 1990's by being the "go to" brand for touring equipment and roof systems. The evolution of the standard product line grew from those early needs in the industry. Over the last several years, Tomcat has invested in keeping 12" and 20.5" plated products in inventory. This has given Tomcat the advantage in the American market to more effectively service the customers that need standard product and still provide high quality custom equipment as well.

You've recently introduced many new products. What are they, how are they special and how do they make the work of riggers easier?

This past year, we released two new products. The first was a standardized Lighting Pod. Over the years, we have done several different versions of these pods for various customers. We decided to take little details from several of those and make a product that would be more standardized.

The Lighting Pod has adjustable lighting fixture mounts within the pod itself, so the fixtures can be placed at various depths within the pod. The pod can be hung vertically to create a more retro wall of light, and it can be hung horizontally, which is more like a traditional truss span. There is also a technician access ladder on the back side of the pod.

The other product is Zig Zag, which is a 40' span of truss that can be pre-rigged with fixtures and cabling, and everything can be unfolded in the venue using chain hoists. In the US, the NBA has embraced this design over the years. And in fact, we just finished prepping a brand new system that the NBA will use for the All-Star game and Finals locations that need better court lighting.

Tomcat has taken part in many interesting projects for their customers. Can you tell us about some of the more recent ones?

Right now, Tomcat is in the middle of several projects. One of the most interesting ones is a large grid system that will be installed at a

new soccer stadium. This is a grid made up of 36" x 24" XHD truss sections with lifting and dead-off points built into the system as needed for connection to the stadium roof. The grid is approximately 124' wide x 64' deep with 35' PA Wings on each side and weighing in at close to 30,000 lbs self-weight. The grid is raised into position using 24 hoists that then dead off with cables. Keep an eye out on A4i.tv, we are working with the customer so that this system can be the subject of a new video soon.

Tomcat has a strong connection with James Thomas Engineering in America. Why is this and how do they differ from each other?

James Thomas Engineering was one of the very first companies manufacturing aluminium truss products in the USA. The customer base that was developed throughout the years at JTE is more geographically located in the eastern part of the country and is fiercely loyal to the brand, with their roots on the standard product line of equipment. Tomcat's customer base grew and became more known for custom work. When Tomcat acquired JTE, there was a big focus on keeping the JTE brand intact to ensure that traditional JTE customers continued to receive the products they were accustomed to. The only thing we changed was that we began polishing all the round tubes before welding, which for years was a feature that set Tomcat apart from other truss manufactures.

What trends are you seeing in our industry and what requests are you receiving more and more often from customers these days?

The industry in the US, and all over the world, has matured greatly over the last 10+ years. Riggers and Technicians are becoming more educated, which has in turn led to responsible manufacturers providing more in-depth training on products and the relevant standards in their region. Customers are coming to Tomcat with more complicated load cases based on how the truss interacts with other elements of the show. Tomcat is lucky to have strong Sales and Engineering Departments with experienced staff that keep up with the demands of today's customers.



EXE
TECHNOLOGY

EXE Technology

EXE Technology is an Italian brand that aggregates a series of companies specialized in the design, engineering and manufacturing of lifting equipment and relevant control systems that handle static & dynamic suspended loads within the entertainment industry.

Their range of products has been developed to safely move and position stage equipment, various types of scenery, video LED walls & other related structures before, during and after professional live performances.

EXE TECHNOLOGY product lines consist of five main families:

- EXE Rise fixed speed electric chain hoists
- EXE Vario variable speed electric chain hoists
- EXE Drive fixed speed power/control unit for chain hoists
- EXE Cell real time load monitoring system (standalone unit or integrated chain hoist device)
- EXE DST Dynamic Stack Tracks, which is a fully integrated system that consists of open faced "trapezoidal" designed truss and a motorized trolley that travels within a built-in track system

It's worth noting the EXE Rise D8+ fixed speed chain hoist family now fully meets the quality standard and working procedures developed by the IGW (Entertainment Technology Industry Association), in cooperation with the DGUV (German Social Accident Insurance) and committee of safety engineers from the German public broadcasting organizations.

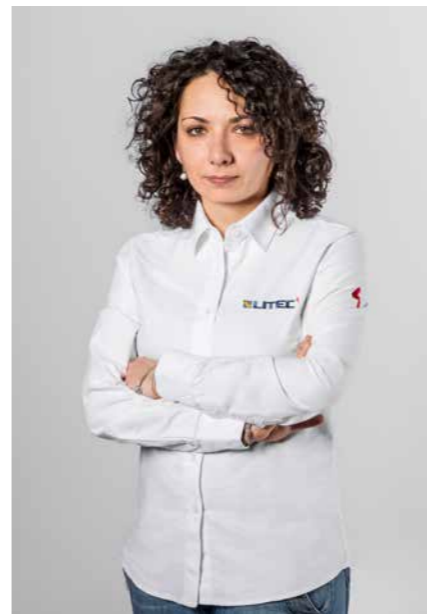

Raffaella Giampaglia

Brand Manager,
EXE Technology

Raffaella talks with us about her responsibilities as Brand Manager and why the EXE Technology range of electric hoists is experiencing such consistent and widespread success around the world.

Can you tell us a little about your daily responsibilities as Brand Manager for EXE Technology?

I'm responsible for the creation of all relevant documentation (risk assessment, declarations of conformity, technical data sheets, test reports, manuals, data plate, etc.), drafting of operational procedures both for internal use and for the end user (ensuring our products provide maximum safety) and market analysis. I also continuously monitor legislation, so we're always a step ahead of our competition in offering our customers a product that is not only unique but also safe and compliant with current regulations. Pre-sales and After-sales technical support for our customers, as well as building and strengthening partnerships with our suppliers are additional responsibilities I have. Non-compliance management and direct collaboration with local authorities and entertainment industry inspectors also falls on my shoulders.

EXE Rise chain hoists have been experiencing an impressive level of success over the past few years. What do you feel has contributed to their success?

I believe the success of the EXE Rise electric chain hoist is due to the five years of close cooperation between the manufacturer, RWM, and its authorized representative, Litec. This collaboration combines the almost half a century of experience RWM has gained in the design and production of industrial lifting equipment, and the twenty years of expertise and international experience Litec Italy has in the design and production of entertainment structures.

How do EXE Rise chain hoists differ from chain hoists from other manufacturers?

We manufacture a product of the highest quality, starting from each individual component (transmission shafts, gear box, load wheel, etc.), which are carefully thought out and designed so the EXE Rise falls into class FEM 2 m (ISO M5) with an IP 55 rating. Even components that are not produced by RWM (brakes, encoders, rectifiers, electrical components, hooks, chains, etc.) are chosen with great care, ensuring their performance maintains the high level of quality and safety EXE Rise chain hoists are now known for around the world.

Their elegant design not only makes them compact and light, but also practical and comfortable during handling and in use; the design of handles that work in both body orientation positions is the latest improvement to their user-friendliness. Another strong point is their security, which has been a driving force for the EXE Technology team in producing a product that is not only safe in operation, but also safe for the user and all persons around the hoist.

What are some other products from EXE Technology?

The fixed speed EXE Rise electric chain hoist range is definitely the best known and most sold around the world. The variable speed EXE Vario electric chain hoist has been developed in recent years and we currently have two models in this range: a 500 kg version with a max. speed of 24 m/min @60 Hz and a 1000 kg version with a max. speed of 12 m/min @60 Hz.

In addition, motor controllers compatible with EXE Rise products, both direct and low voltage control versions, belong to the EXE Drive range. EXE Drive is available in a wide variety of models, ranging from 1 to 24 linkable or non-linkable channels. Another workhorse of the EXE Technology product range is the load cell with display interface, which is compatible with the EXE Rise medium and large frame chain hoists. The load cell, together with the load cell system with shackle, form the EXE Cell range.

The last member of the family is the EXE DST (Dynamic Stack Tracks) range that includes all products that allow for the up/down, right/left and 360° rotation of loads, LED screens, scenery and projection screens for concerts and other events. You can find images and details of all products in the EXE Technology family on our website at www.exetechnology.com.

What does the future hold for the EXE Technology brand and its products?

The EXE Technology team is constantly working to introduce new products on the market that bring innovation and safety to new levels. In fact, the 2019 Prolight + Sound exhibition will be the debut of the new EXE Rise D8+ 2000 kg DC/LVC single fall chain hoist. In addition, we currently have many studies and projects underway to expand the EXE DST range, in particular for the DST 66 models.

All Area Four Industries distribution offices are now called...

Area Four Industries Direct

At the end of 2018, Area Four Industries distribution offices located in Germany, the U.K. and the United States added "Direct" to their names to provide a clear distinction between their operations and the Area Four Industries "Think Tank" headquarters based in the Czech Republic.

This name change does not affect the basic operation of the distribution offices, as they still provide access to their brands' product lines, full technical support, and an open door to each brand's design and engineering departments for custom and bespoke projects.

Each of the Area Four Industries Direct offices have also launched their own websites, which are dedicated to their respective territories and feature the brands they distribute. You can find them at the website addresses below.

Area Four Industries Direct Germany: www.areafourindustries.de

Area Four Industries Direct UK: www.areafourindustries.co.uk

Area Four Industries Direct America: www.areafourindustries.us

All websites feature the complete range of products from each brand the office distributes, brand news, overview of technical support, and full contact information.

Discover the advantages Direct delivers!



Jan-Dirk Hachmann
Commercial Director,
Area Four Industries Direct
Germany

Can you tell us about the activities your office carried out in 2018?

One of the highlights was delivery of another Ninja Course using Milos truss in a trampoline park here in Germany, where we worked closely with our customer from the initial idea to the technical and static calculations, and all the way up to final production.

We also had our first sale of products from the Milos steel truss line to our customer Malecon, which purchased almost 100 m of Milos M1450 S-RTW steel truss. Its first use was at a concert of the well-known German band PUR in the Westfalenhalle in Dortmund with a pre-rig that had a span of 42 m.

Another customer I would like to highlight is Barowski AG, which had purchased two free-standing Milos steel truss PA Towers from us. Each PA Tower is 16 m high and has a loading capacity of 2500 kg.

What would you consider the biggest asset of your office and the value you provide to customers?

Our biggest benefit is that we can offer our customers a complete solution. True to the Area Four Industries motto "You know what. We know how.", we are able to meet the requirements given by our customers and provide both the products and services they need for their small to large projects. In fact, we not only deliver the products each customer needs, but also develop individual solutions in partnership with them in terms of engineering and static calculations.

How do you see your business developing in the future?

I see our office very well-positioned for the future. We have a highly talented team and a great customer base, which we intend to expand even further in the coming years.



Glen Brown
UK Sales & Marketing Director,
Area Four Industries Direct
United Kingdom

Can you tell us about the activities your office carried out in 2018?

The beauty of our vast portfolio of products creates a perfect diversity of industries, which generally peak at different times of the year or create some interesting production challenges when they all collide! A busy start in exhibitions was quickly followed with frantic outdoor and live event seasons. Within the Area Four Industries umbrella, there is a solution for every project, for all markets, wherever in the world.

What would you consider the biggest asset of your office and the value you provide to customers?

Area Four Industries UK is a UK office for UK clients, we have immediate stock availability for a rapid response. Essentially with Area Four Industries Direct UK, you are dealing with four manufacturers via dedicated brand managers and support staff, closely flanked by the extensive resources of each brand's manufacturing facilities.

How do you see your business developing in the future?

In recent years, the trend across the industry is the shortening of lead times on projects. We now commonly describe ourselves as an emergency service. Projects can often come out of nowhere, but with our multiple mega production facilities generally we can manage, but it can be a tight call. And similar to many manufacturing and distribution services, we have prepared as much as possible for "BrexSh*t" with increased inventory to avoid any delays during the transition period.

We enter 2019 stronger than ever before and more technically advanced to solve all challenges in front of us.



Adrian Forbes-Black
Vice-President – Sales
& Marketing, Area Four Industries
Direct America

Can you tell us about the activities your office carried out in 2018?

Well, the majority of my time in 2018 was spent physically opening our new Californian sales office and warehouse (Area Four Industries Direct America West), so the past 12 months have all been about hiring people and getting inventory on the floor.

What would you consider the biggest asset of your office and the value you provide to customers?

Location, location, location! The new Area Four Industries Direct America West office and warehouse is located in Thousand Oaks, California, which is around a 45 minute drive north west of downtown Los Angeles, Hollywood, etc. That puts us in the middle of around 19 million people in the Greater Los Angeles area and also puts us right into the middle of what is known worldwide as the epicenter of the global entertainment industry. This cuts down delivery times, and therefore costs to our customers. It also makes members of our sales staff, and not just the products, more accessible now they are physically based in the Pacific Time Zone.

Between the office and warehouse based in Knoxville, Tennessee (Area Four Industries Direct America East), and this new office, we have people in the United States answering phones for at least twelve hours a day. And all sales folks have access to the same information on inventory availability in both locations.

How do you see your business developing in the future?

I think our biggest strength is our people and I'm really proud of my sales and technical support team. I also believe that Area Four Industries' model of providing regional sales offices and warehouses with experts, technicians and designers available immediately at the end of an e-mail or telephone, will pay dividends when compared to some of our competitors who only want to sell on price.

Milos delivers the power of steel

The worldwide market for events is becoming larger every year as artists depend more on income via concerts, not to mention electronic dance music as a real upcoming force in live events. This market requires higher and higher loads, as well as taller and taller structures.

Through the use of very special steel alloys, Milos has developed a new steel truss line. Steel truss is able to handle an average of 2.5x more load at just double the weight compared to aluminium systems with the same dimensions and under the same deflection. In a newly dedicated part of their factory, they are producing these steel truss elements under TUV monitoring and according to EN1090.

Each steel truss section features double fork couplers, orientation-free connectors, integrated forklift pickup points, and an extremely durable, matt black, impact-resistant industrial paint finish. It's optimized webbing pattern allows for easy assembly of cross trusses, and its end braces feature 16 mm holes for lateral connections. Not to mention optimized dimensions for packaging and/or nesting in trucks.

The steel truss towers are also extremely impressive, reaching heights up to 20+ metres, handling loads up to 40+ tons, and achieving 60+ metre spans (60 metre spans with UDL 140 kg/m). The tower's head section is equipped with wheels for double fall chain hoists, which can lift up to 10 tons with a 2.5 ton chain hoist. A multi-directional sleeve block with a mechanical safety lock system that prevents drop and lift is also a unique feature in the tower system.

The new steel truss line from Milos is appreciated and valued by both customers and industry professionals alike. In fact, Milos is the only truss manufacturer in the world that has a steel truss line as part of its standard offer of truss.

With the introduction of the new steel truss line from Milos, the most demanding events in live entertainment have met their match!



Worldwide Debut of Milos Steel Truss – German Unity Festival (Berlin, Germany)

The worldwide debut of two Milos Steel Truss towers took place in Berlin, for the German Unity Day – the largest festival of the year in Germany! The 20 metre high Steel PA towers, which flanked both sides of a massive stage, were constructed with Milos S-M780 Quatro steel truss that supported 2,500 kg of PA and featured a front surface area of 10 m², side surface area of 5 m², and a 2 metre cantilever.

Each tower has a multi-directional sleeve block with a mechanical safety lock system that prevents drop and lift. The sleeve block is able to support a total of 40 tons per tower, with the cross beam able to support a centre point load of up to 6,500 kg on a 50 metre span.

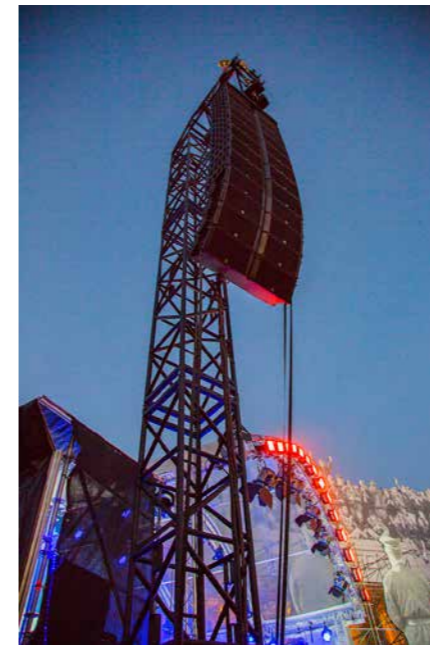

Supporting pop rockers "PUR" in Germany

Milos 145REC S-RTW Steel Truss was used to create two 42 m spans for a sold out concert of the famous German pop rock group "PUR" at Dortmund Westfalenhalle. Each span was rated for total load of 9,000 kg.

As the venue is almost 60 years old, and did not have enough loading capacity to support the equipment needed for the concert, the high capacity steel truss from Milos was used to ensure the loads were kept as far as possible from the centre of the roof to reduce stress on the roof structure.

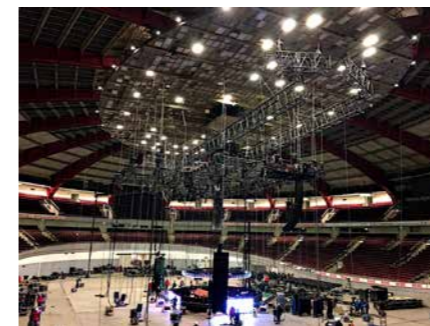



**“Velvet Backstage”
Sharing our
knowledge
and experience**

Area Four Industries Technical Director, Dipl.-Ing. Norbert Tripp, gives us a glimpse into how Area Four Industries promotes and ensures safety in the manufacture of truss and rigging products by its brands, as well as the continuous education of their extensive user base.

Area Four Industries always strives for a high level of safety. There is no question that the phrase “safety of buildings and structures” is first and foremost based on the use of safe products. Therefore, the highest possible level of safety standards is taken into account in the manufacture and development of our brands’ products. This starts with the monitoring of our products from suppliers, continues through to the internal safety and quality mechanisms, and finally to the certification of our production facilities and employees.

However, the safety of buildings and structures does not stop with the products. It is also based on the qualification and expertise of the users. It goes without saying that only those who understand the products can use them correctly and safely. This “understanding” refers first and foremost to the practical functionality and handling of the product. For this reason, we are currently working intensively on creating user manuals for our products that are unparalleled in the industry. These user manuals will enable a qualified risk assessment to be carried out, which serves as the basis for safe assembly, use and disassembly.

Compared to other industries, ours is still quite young. Many older colleagues and friends, who have been working in the event industry since the 1980s, gained their qualification status according to the principle of “learning by doing”. Nowadays, there is the possibility to complete official vocational training in Germany, as well as in Europe and the USA, or to further one’s knowledge in a wide variety of organizations and companies.

Area Four Industries, for example, offers various training opportunities at our facilities in the Czech Republic, China and America. These include the well-regarded Tomcat U training workshop, which has gained

legendary status in the United States and is held by our American brand Tomcat. At their factories in the Czech Republic and China, Milos also holds its annual Product Academy, which is not only a presentation of Milos products, but also includes educational training. Finally, the “Rigger’s Voice” forum held at Area Four Industries Headquarters is an event that goes well above the level of education. This forum provides a platform for highly qualified riggers and planners to network and exchange knowledge, as well share experience and discuss the latest developments in rigging. Rigger’s Voice is rounded off by stress tests on truss in different test setups.

Our recently launched www.A4i.tv internet TV channel offers additional opportunities for us to pass on our knowledge and experience to information hungry users, as well as users from other regions of the planet that do not have an opportunity to attend our trainings and workshops. With www.A4i.tv, we can reach virtually every corner of the world where the internet is accessible.

The challenge with the videos on A4i.tv is to communicate content in a simple and understandable way, and in a short amount of time. This seems to be a relatively easy exercise with a product presentation, but with a theoretical topic, it is more difficult. Viewers naturally have different levels of experience, which is why I have to start with the basics for some videos. On the other hand, the content is sometimes very complex, which makes it difficult to keep everything simple and not have the video run longer than 3–5 minutes. I like to use props in my videos, rather than thousands of words, which make the more difficult subjects easier to illustrate.

Going forward, we will continue making our knowledge and experience accessible to help in further increasing the level of safety and professionalism in our industry.

Customer Challenges



Vladimir Zeman

Technical Director, Milos

Vladimir exposes all of the "secret" work that Head of Engineering is responsible for within a major truss production facility.

You are Head of Engineering for Milos, one of the major truss brands on the world market. Can you tell us a little about your responsibilities and all of the behind the scenes work carried out at Milos?

I've worked at Milos since 1999, and can say after all of this time that no two days are the same. That is one of the main reasons I still enjoy my job and look forward to coming to work every day.

The engineering part of my job involves custom projects for many of our customers around the world, as well as carrying out research and development activities for new Milos products and structures. For the custom and bespoke projects, I am responsible for analyzing our customer's requirements to see if we can meet their demands with an existing standard product, modify an existing product, or develop something totally new. We work closely with the customer and use internal specialists, such as our in-house Structural Engineer, to bring the project to a successful conclusion.

For our research and development activities, we have a dedicated team of specialists that analyze feedback from customers, gather the results of custom projects we perform, and introduce many of their own ideas to develop new products that can be brought to market, usually between 5-10 new Milos products every year.

As welding is the largest part of our production process, activities related to this activity take up a large amount of my time. This involves the qualification and specification of welding procedures for both our aluminium, and most recently steel, products. In fact, the training and certification of steel welders was a very time consuming and expensive process for us, as steel welding requires very special equipment and skills that go well beyond the aluminium welding that we've done for so many years.

My job responsibilities also spill over to the actual welding process, which include inspection and testing. I need to define the basic welding parameters (eg. welding current, arc tension, welding speed), preheating temperature and interpass temperature, the cleanliness and shape of the weld bead and weld metal, sequence of welding, the proper use and handling of the welding and auxiliary materials, deformation control, and any inter-operative checks that could be required, such as dimension checks.

Once the welding process is complete, it is necessary to inspect and test all products

before they go out the door. Therefore, I manage the visual inspection, non-destructive testing, check of the shape/design/deviation/dimensions of the product or structure, and the results and records of processing after welding is complete.

After these inspections and tests are complete, potential corrective actions are taken so our products meet with the stringent quality requirements Milos demands, such as weld repairs, inspections of repaired welds, etc.

The final part of the production process, and the last category of my job responsibilities, involves management of identification and traceability of all products that come out of our production hall. This includes identification of all accompanying documents, location of welds on the product or structure, non-destructive testing procedures and personnel, welding and auxiliary materials, basic materials used in production, repaired areas, location of temporary connections, and procedures followed during the production process. I also ensure that all quality and maintenance records are prepared and filed.

After almost two decades of working in this role, I take comfort in knowing that our engineering and production hall work hand in hand and are producing some of the highest quality truss and support structures on the world market. I will let our products and many satisfied customers around the world serve as my legacy.



Norbert Tripp

Technical Director, Area Four Industries

Norbert explains the concept and content of the annual "Rigger's Voice" forum held at Area Four Industries Headquarters in Roudnice nad Labem, Czech Republic.

Hi Norbert. The second annual Rigger's Voice forum recently took place at the A4I Headquarters in Roudnice nad Labem, Czech Republic. Can you tell us a little about what's behind the naming of this forum?

As the name suggests, it's basically an idea of how we can help amplify the voice of leading riggers' that work with our products on a daily basis, the people who actually build the support structure and implement the equipment in terms of craftsmanship and planning.

Our aim with Rigger's Voice is to offer leading riggers in our industry a platform to network with each other, exchange professional experience and gather new experience. All combined with a pleasant atmosphere and an accompanying program.

That sounds very noble, but what value does this bring to Area Four Industries?

First of all, we want to hear about trends within the industry from people who are on the ground and have a great deal of experience working with our products. We wish to find out what topics are important for them, and what details they focus on. We then analyse this feedback and implement it into development of new products for the brands in our group.

How did you organize the forum and what exactly did you do?

All participants arrive the night before the start of the forum, which begins at 9 am. After a short introduction, we take them on a guided tour of the Milos factory. For most of them, the area of the factory where Milos produces their steel truss was especially interesting and impressive.

The rest of the first day was spent discussing practical issues in a relaxed atmosphere. These included concrete technical questions, as well as general topics, such as current revisions in standards.

What about the second day?

Most of the second day was allocated to stress tests. As the criteria for discarding truss was discussed earlier, we included truss that had been deliberately damaged for this previous discussion and used them for testing. In this way, we were able to clearly demonstrate what type of damage leads to what type of failure.

After each test was completed, participants were allowed to inspect the truss and hold discussions between themselves, as well as asking my colleague André Schniedergers and myself questions, as we are both Structural Engineers. In fact, almost everyone in attendance was interested in taking a closer look at the damaged truss.

You've already conducted two forums. Were there any differences between them?

Actually, the programs were almost identical. The participants made the difference. During last year's forum, participants had more technical, static and functional questions, which resulted in long and intense discussions. For this year's forum, current developments and questions about them were more prevalent.

The composition of the group also differed. The first forum had a total of 16 participants from 4 or 5 different companies. This year, there were 17 participants from 12 companies. In fact, we actually managed to bring together a top-class group of participants from Germany for this year's forum.

You mentioned at the beginning of this interview that there was an accompanying programme for the forum. Can you tell us about it?

At the end of the first day, Area Four Industries Communications Specialist David Gore came into the room with a big wheelbarrow of iced down beer and led a brief beer tasting with 7 different Czech craft beers.

We then left for the evening program, which started with a one-hour evening boat trip through the centre of Prague, followed by dinner at a typical Czech restaurant. All of the riggers, as well as staff from Area Four Industries and our Milos brand, really enjoyed the evening and got to know each other better.

It definitely sounds like all parts of the forum were a success. What are your plans for Rigger's Voice in the future? Will you have another in 2020?

Nothing has been decided yet, but I can imagine that after focusing on the UK and Germany the past two years, we would be inclined to invite a group of top riggers from a different region in 2020.

Why work with us?

If you would like to experience what it's like to work behind the scenes in the wonderful world of entertainment, then contact us and take a step into this exciting industry! Truss and support structures are the backbone of the entertainment industry and are an integral part of all indoor and outdoor live events around the world. **Area Four Industries** and its eight brands are leaders on the market and offer interesting career opportunities to those who are ready to meet the challenges within this fun and progressive industry.

If you're ready to be part of the industry that provides structural support to today's top artists and live performers, send us an e-mail or give us a call today!

Email: info@areafourindustries.com
Phone: +420 416 837 846

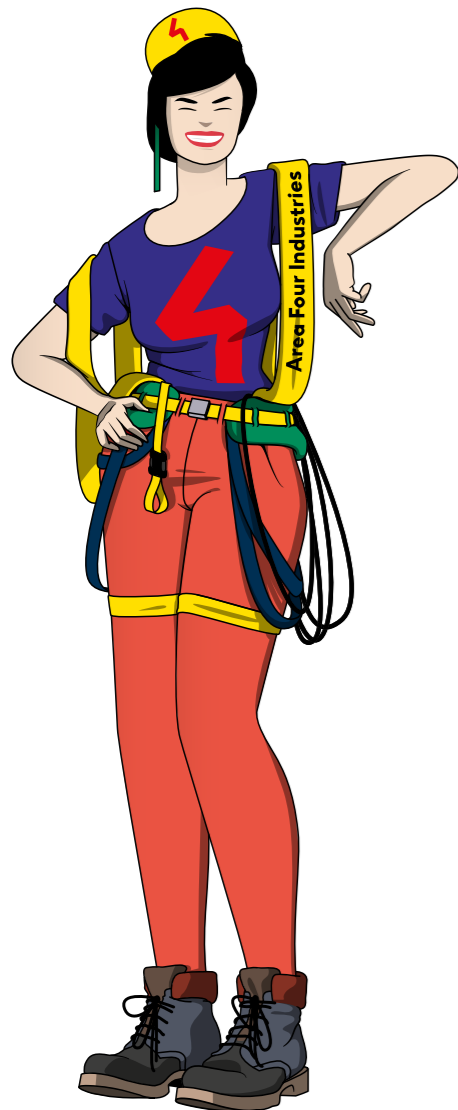

Milos
Jirka Spacil
Technical Preparation
and Semi-Automatic Machine Operator

How long have you worked at Milos?
I've worked at the Milos factory for a total of 18 years.

Why did you decide to work at Milos?
I enjoy technology, design and mathematics, and learning the most I can about each of them. With my job at Milos, I'm able to take the knowledge I've gained in these areas and have it flow through my hands into the products we manufacture. It's the perfect medium for taking design and mathematics, and delivering them into the real world.

What do you like most about your job?
In addition to my daily job responsibilities, which I really like, I also appreciate the tight knit team I work with. My colleagues and I enjoy each other's company both inside and outside of the workplace.



Barbora Labutova
Designer/Technology Specialist

How long have you worked at Milos?
I graduated from the Secondary School of Packaging Technology in 2004 and started working at Milos immediately afterwards as a designer. So a total of 15 years.

Why did you decide to work at Milos?
The job seemed really interesting and challenging. I also liked the idea that I would be helping to come up with solutions for customer requests.

What do you like most about your job?
I really enjoy working on custom jobs, which range from large roofing (eg MR5 31 x 18 in Romania) to small, customized parts, and like to hear that the customer was satisfied with our work.

I also like working with the design software program Invector, because it is a virtual world of clear rules and principles that has no traces of disorganization or chaos, which I like to avoid in my life. And maybe that's the reason I'm in charge of all Milos technical documentation :-)



Litec
Orietta Rosso
Account Manager Export/Domestic

How long have you worked at Litec?
I have been working at Litec since 2007.

Why did you choose to work at Litec?
Litec had always been internationally known as a leader in the industry and I was drawn to its reputation of being one of the leading truss manufacturers on the market. It has an impressive list of customers and a high rate of customer satisfaction.

What do you like most about your work?
I really believe in the value of teamwork and working with other people towards a common goal. And I love listening to customers so we can identify and meet their needs. I devote most of my working time to serving our customers and ensuring their satisfaction. Customers are the foundation of success for any business and communication is key in building and maintaining long-term relationships with them.



Tomcat
Aaron Willard
CAD Operator

How long have you worked at Tomcat?
It seems that I've been working here for ages, but it's only been 3 years.

Why did you choose to work at Tomcat?
I wanted to learn a new trade and the offer of designing products in 3D was very appealing to me. It's really rewarding to design a product within the virtual world and then see it come to life in the Tomcat factory.

What do you like most about your job?
I guess you could say the enjoyment of working with truss and support structure products, combined with the laid back atmosphere that makes it easier and more productive to get jobs/projects done. Everyone is willing to help when needed or in the event that any problems arise. It's great to work for a place, and with people, that appreciate who you are and what you do.



JTE
Michael Davis
Customer Service Representative

How long have you worked at JTE?
I've been on the job for 5 years and counting.

Why did you choose to work at JTE?
I wanted to get into the entertainment industry and JTE offered me an amazing opportunity to dive in. After 5 years on the job, I still consider it a decision well made.

What do you like most about your job?
I enjoy working with my many colleagues, who have now become great friends over the years. And, of course, I really enjoy working with our customers on a daily basis and getting to know them. I'm happy to provide the service they require regarding our wide range of products or helping answer questions they may have while working on location with our products.



Cristina Villa
Customer Care

How long have you worked at Litec?
I have been happily working for Litec since April 2006.

Why did you decide to work at Litec?
It was just by chance. My previous work experience was in totally different fields, which were technically-oriented and not within this industry. I must say that I am very happy to have been given the opportunity to work here and discover the normally "hidden" world of entertainment. When I started working at Litec, my colleagues introduced me to trussing products and told me, "Just imagine that you are in the world of Lego". I found the comparison quite funny, but at the same time it aroused my curiosity. Lego suggested "creativity" and that was very interesting for me.

What do you like most about your job?
First of all, I am proud to be part of a very good team. Timeliness, good service, and high quality products are all extremely important in our world and make my job very dynamic and exciting. I have always been involved in sales, and I like the human relationship aspect it brings to my job.



Tonya Ballew
Human Resources Manager

How long have you worked at Tomcat/JTE?
I've been managing human resources, as well as many other things, for the past five years.

Why did you choose to work at Tomcat/JTE?
Tomcat has a wonderful reputation as a great place to work. High value is placed on employees, encouraging them to grow and innovate inside the company. Employees happily work here for years, far beyond the average length one normally stays with one employer. According to our customers, the high quality of our products and services reflect high employee satisfaction.

What do you like most about your job?
I enjoy working with a team of very talented people in an extremely positive environment. The team environment is very strong at Tomcat, along with the flexibility and freedom to challenge our limits.



Chad Kramer
CAD Operator

How long have you worked at JTE?
I've been here for 2 years and my colleagues still jokingly refer to me as the rookie.

Why did you choose to work at JTE?
JTE have a long history in this business and a great reputation. This is what initially drew me to them, as I wanted to work with a company that would provide proper and valuable experience.

What do you like most about your job?
I certainly enjoy working with JTE's products and customers, but I also have to say that my colleagues are truly amazing. I couldn't ask to work with a better group of people.



Distribution offices

- 1 Area Four Industries Direct**
United Kingdom

Unit 5-6 Beechwood Estate
Cattle Dyke, Gorefield Wisbech
Cambridgeshire PE13 4NR
United Kingdom
- 2 Area Four Industries Direct**
Germany

Johann-Krane-Weg 27
Münster 48149
Germany
- Area Four Industries Direct**
America
- 3 East**
5427 N. National Dr.
Knoxville, TN 37914
USA
- 4 West**
950 Lawrence Drive, Suite B
Thousand Oaks, CA 91320
USA
- 5 Area Four Industries**
Headquarters

Spindlerova 286
Roudnice nad Labem 413 01
Czech Republic

Manufacturers

- 5 Milos**

Spindlerova 286
Roudnice nad Labem 413 01
Czech Republic
- 6 Milos**
China

House No.1-3, 6 Gong-Ye Road,
Da-Wen Cun
Dong-Chong Zhen,
Nansha district, Guangzhou
China
- 3 Tomcat**

5427 N. National Dr.
Knoxville, TN 37914
USA
- 7 Litec**

Via Martin Luther King, 70
31032 Casale sul Sile (TV)
Italy
- 7 James Thomas Engineering EMEA**
Europe, Middle East and Africa

Via Martin Luther King, 70
31032 Casale sul Sile (TV)
Italy
- 3 James Thomas Engineering USA**
The Americas, Asia, Australia

5427 N. National Dr.
Knoxville, TN 37914
USA